

**SECCION 1.2 SOPORTERIA PARA CABLES TIPO FONDO SOLIDO Y FONDO VENTILADO**

**SECTION 1.2 CABLE TRAY SYSTEM SOLID AND VENTILATED BOTTOM TYPE**

**SECCIONES TIPO "Z"**

**FORM "Z" SECTIONS**



PERALTE NOMINAL SIZE HEIGHT	TIPO DE FONDO BOTTOM TYPE		SUBFIJO P/PERALTE RAIL HEIGHT SUFFIX	CLASE NEMA NEMA CLASS	
	LISO SOLID	VENTILADO VENTILATED		ALUMINIO ALUMINUM	ACERO STEEL
82.5 (3.25)	ZL	ZP	1	12A	12B
101.6 (4)	ZL	ZP	2	12B	12C
114.3 (4.5)	ZL	ZP	3	12B	12C
127.0 (5)	ZL	ZP	5	12C	20A
152.4 (6)	ZL	ZP	6	16C	20B

**SECCIONES TIPO "C"**

**FORM "C" SECTIONS**



PERALTE NOMINAL SIZE HEIGHT	TIPO DE FONDO BOTTOM TYPE		SUBFIJO P/PERALTE RAIL HEIGHT SUFFIX	CLASE NEMA NEMA CLASS	
	LISO SOLID	VENTILADO VENTILATED		ALUMINIO ALUMINUM	ACERO STEEL
82.5 (3.25)	CL	CP	1	12A	12B
101.6 (4)	CL	CP	2	12B	12C
114.3 (4.5)	CL	CP	3	12B	12C
127.0 (5)	CL	CP	5	12C	20A
152.4 (6)	CL	CP	6	16C	20B

CUANDO EL PRODUCTO ES FABRICADO DE ALUMINIO  
PARA ANCHO DE 101.6 (4) A 228.9 (9) LAMINA CAL 16  
PARA ANCHOS DE 304.8 (12) A 914.4 (36) LAMINA CAL. 14

WHEN THE RAW MATERIAL IS ALUMINUM  
FOR 101.6 (4) TO 228.9 (9) WIDTH WE USE SHEET 16GA  
FOR 304.8 (12) TO 914.4 (36) WIDTH WE USE SHEET 14GA

PARA ACERO EN TODOS LOS ANCHOS LAMINA CAL 14

FOR STEEL IN ALL WIDTH 14 GA IS USED

MATERIALES Y ACABADOS DISPONIBLES:  
A: ALUMINIO ALEACION AA-6063 ACABADO NATURAL

MATERIALS & FINISHES AVAILABLE :  
A: AA-6063 NATURAL FINISHED ALUMINUM

GI : ACERO AL CARBONO GALVANIZADO POR INMERSION  
EN CALIENTE SEGUN ASTM A 525

GI : HOT DIP GALVANIZED STEEL UNDER ASTM A 525

GE : ACERO AL CARBONO GALVANIZADO ELECTROLITICO  
SEGUN ASTM B 633

GE : ELECTROGALVANIZED STEEL UNDER ASTM B 633

T : ACERO AL CARBONO TROPICALIZADO

T : CHROMIUM-ZINC COATED STEEL

AI : ACERO INOXIDABLE ACABADO NATURAL

AI : NATURAL FINISHED STAINLESS STEEL

PARA MATERIALES Y ACABADOS NO INDICADOS CONSULTE NUESTRO DEPARTAMENTO DE INGENIERIA  
FOR MATERIALS AND FINISHES NOT SHOWN. PLEASE CONSULT OUR TECHNICAL DEPARTMENT

TODAS LAS DIMENSIONES EN mm (Pulg) ALL DIMENSIONS ARE IN mm (Inch)

**TRAMO RECTO**

**STRAIGHT SECTION**

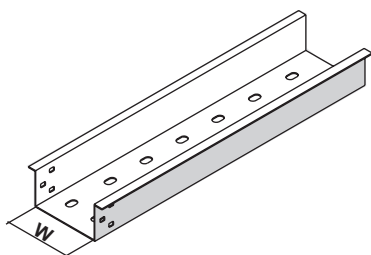

**CHZL-12-1GI**

MATERIAL Y ACABADO (VER PAG 20) MATERIAL & FINISHES (SEE PAGE 20)  
 SUBFIJO P/PERALTE (VER PAG 20) RAIL HEIGHT SUFFIX (SEE PAGE 20)  
 ANCHO WIDTH  
 TIPO DE FONDO (VER PAGINA 20) BOTTOM TYPE (SEE PAGE 20)  
 TRAMO RECTO STRAIGHT SECTION

LONGITUD ESTANDARD 3.048 m (10 PIES)  
 STANDARD LENGHT 3.048 m (10 ft)

PARA LONGITUDES DIFERENTES CONSULTE  
 NUESTRO DEPARTAMENTO DE INGENIERIA  
 FOR OTHER LENGHT PLEASE CONSULT  
 OUR TECHNICAL DEPARTMENT

INCLUYE 2 CONECTORES Y TORNILLERIA  
 TWO CONNECTOR AND HARDWARE INCLUDED

ANCHO W WIDTH W	PERFIL TIPO Z FORM Z		PERFIL TIPO C C FORM	
	LISO SOLID	VENTILADO VENTILATED	LISO SOLID	VENTILADO VENTILATED
101.6 (4)	CHZL-04	CHZP-04	CHCL-04	CHCP-04
152.4 (6)	CHZL-06	CHZP-06	CHCL-06	CHCP-06
228.9 (9)	CHZL-09	CHZP-09	CHCL-09	CHCP-09
304.8 (12)	CHZL-12	CHZP-12	CHCL-12	CHCP-12
406.4 (16)	CHZL-16	CHZP-16	CHCL-16	CHCP-16
457.2 (18)	CHZL-18	CHZP-18	CHCL-18	CHCP-18
508.0 (20)	CHZL-20	CHZP-20	CHCL-20	CHCP-20
609.6 (24)	CHZL-24	CHZP-24	CHCL-24	CHCP-24
762.0 (30)	CHZL-30	CHZP-30	CHCL-30	CHCP-30
914.4 (36)	CHZL-36	CHZP-36	CHCL-36	CHCP-36

**CURVA HORIZONTAL A 45° Y 90°**

**45° & 90° HORIZONTAL BEND**

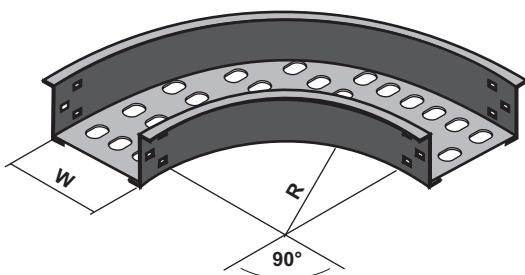

**VHZP-12R890-1GI**

MATERIAL Y ACABADO (VER PAG 20) MATERIAL & FINISHES (SEE PAGE 20)  
 SUBFIJO P/PERALTE (VER PAG 20) RAIL HEIGHT SUFFIX (SEE PAGE 20)  
 ANGULO DE LA CURVA ANGLE BEND  
 RADIO RADIUS  
 ANCHO WIDTH  
 TIPO DE FONDO (VER PAGINA 20) BOTTOM TYPE (SEE PAGE 20)  
 CURVA HORIZONTAL HORIZONTAL BEND

**NUMEROS DE CATALOGO PARA CURVA A 90° 90° BEND CATALOG NUMBER**

ANCHO W WIDTH W	RADIO RADIUS			
	203.2 (8)	304.8 (12)	609.6 (24)	914.4 (36)
101.6 (4)	VH**-04R890	VH**-04R1290	VH**-04R2490	VH**-04R3690
152.4 (6)	VH**-06R890	VH**-06R1290	VH**-06R2490	VH**-06R3690
228.9 (9)	VH**-09R890	VH**-09R1290	VH**-09R2490	VH**-09R3690
304.8 (12)	VH**-12R890	VH**-12R1290	VH**-12R2490	VH**-12R3690
406.4 (16)	VH**-16R890	VH**-16R1290	VH**-16R2490	VH**-16R3690
457.2 (18)	VH**-18R890	VH**-18R1290	VH**-18R2490	VH**-18R3690
508.0 (20)	VH**-20R890	VH**-20R1290	VH**-20R2490	VH**-20R3690
609.6 (24)	VH**-24R890	VH**-24R1290	VH**-24R2490	VH**-24R3690
762.0 (30)	VH**-30R890	VH**-30R1290	VH**-30R2490	VH**-30R3690
914.4 (36)	VH**-36R890	VH**-36R1290	VH**-36R2490	VH**-36R3690

**NUMEROS DE CATALOGO PARA CURVA A 45° 45° BEND CATALOG NUMBER**

ANCHO W WIDTH W	RADIO RADIUS			
	203.2 (8)	304.8 (12)	609.6 (24)	914.4 (36)
101.6 (4)	VH**-04R845	VH**-04R1245	VH**-04R2445	VH**-04R3645
152.4 (6)	VH**-06R845	VH**-06R1245	VH**-06R2445	VH**-06R3645
228.9 (9)	VH**-09R845	VH**-09R1245	VH**-09R2445	VH**-09R3645
304.8 (12)	VH**-12R845	VH**-12R1245	VH**-12R2445	VH**-12R3645
406.4 (16)	VH**-16R845	VH**-16R1245	VH**-16R2445	VH**-16R3645
457.2 (18)	VH**-18R845	VH**-18R1245	VH**-18R2445	VH**-18R3645
508.0 (20)	VH**-20R845	VH**-20R1245	VH**-20R2445	VH**-20R3645
609.6 (24)	VH**-24R845	VH**-24R1245	VH**-24R2445	VH**-24R3645
762.0 (30)	VH**-30R845	VH**-30R1245	VH**-30R2445	VH**-30R3645
914.4 (36)	VH**-36R845	VH**-36R1245	VH**-36R2445	VH**-36R3645

INCLUYE 2 CONECTORES Y TORNILLERIA TWO CONNECTOR AND HARDWARE INCLUDED  
 TODAS LAS DIMENSIONES EN mm (Pulg) ALL DIMENSIONS ARE IN mm (Inch)

**CURVA VERTICAL EXTERIOR A 45° Y 90°**

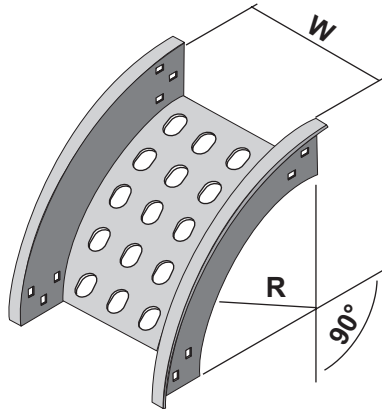

**45° & 90° OUTSIDE VERTICAL BEND**

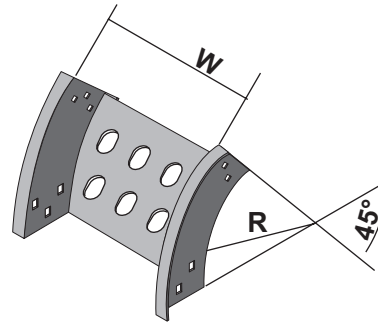

**VEZP-12R890-1GI**

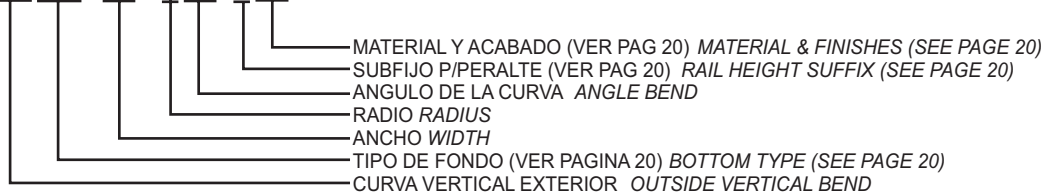

**NUMEROS DE CATALOGO PARA CURVA A 90° 90° BEND CATALOG NUMBER**

ANCHO W WIDTH W	RADIO RADIUS			
	203.2 (8)	304.8 (12)	609.6 (24)	914.4 (36)
101.6 (4)	VE**-04R890	VE**-04R1290	VE**-04R2490	VE**-04R3690
152.4 (6)	VE**-06R890	VE**-06R1290	VE**-06R2490	VE**-06R3690
228.9 (9)	VE**-09R890	VE**-09R1290	VE**-09R2490	VE**-09R3690
304.8 (12)	VE**-12R890	VE**-12R1290	VE**-12R2490	VE**-12R3690
406.4 (16)	VE**-16R890	VE**-16R1290	VE**-16R2490	VE**-16R3690
457.2 (18)	VE**-18R890	VE**-18R1290	VE**-18R2490	VE**-18R3690
508.0 (20)	VE**-20R890	VE**-20R1290	VE**-20R2490	VE**-20R3690
609.6 (24)	VE**-24R890	VE**-24R1290	VE**-24R2490	VE**-24R3690
762.0 (30)	VE**-30R890	VE**-30R1290	VE**-30R2490	VE**-30R3690
914.4 (36)	VE**-36R890	VE**-36R1290	VE**-36R2490	VE**-36R3690

**NUMEROS DE CATALOGO PARA CURVA A 45° 45° BEND CATALOG NUMBER**

ANCHO W WIDTH W	RADIO RADIUS			
	203.2 (8)	304.8 (12)	609.6 (24)	914.4 (36)
101.6 (4)	VE**-04R845	VE**-04R1245	VE**-04R2445	VE**-04R3645
152.4 (6)	VE**-06R845	VE**-06R1245	VE**-06R2445	VE**-06R3645
228.9 (9)	VE**-09R845	VE**-09R1245	VE**-09R2445	VE**-09R3645
304.8 (12)	VE**-12R845	VE**-12R1245	VE**-12R2445	VE**-12R3645
406.4 (16)	VE**-16R845	VE**-16R1245	VE**-16R2445	VE**-16R3645
457.2 (18)	VE**-18R845	VE**-18R1245	VE**-18R2445	VE**-18R3645
508.0 (20)	VE**-20R845	VE**-20R1245	VE**-20R2445	VE**-20R3645
609.6 (24)	VE**-24R845	VE**-24R1245	VE**-24R2445	VE**-24R3645
762.0 (30)	VE**-30R845	VE**-30R1245	VE**-30R2445	VE**-30R3645
914.4 (36)	VE**-36R845	VE**-36R1245	VE**-36R2445	VE**-36R3645

INCLUYE 2 CONECTORES Y TORNILLERIA TWO CONNECTORS AND HARDWARE INCLUDED

TODAS LAS DIMENSIONES EN mm (Pulg) ALL DIMENSIONS ARE IN mm (Inch)

**CURVA VERTICAL INTERIOR A 45° Y 90°**

**45° & 90° INSIDE VERTICAL BEND**

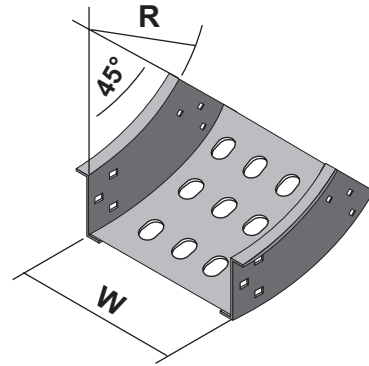
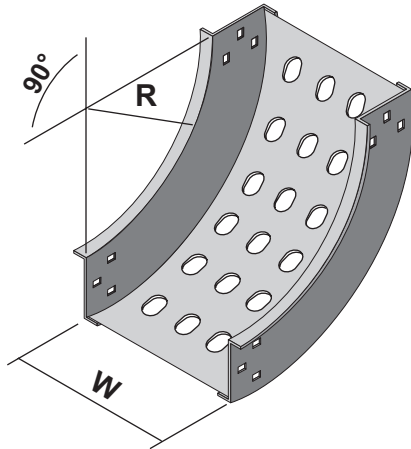

**VIZP-12R890-1GI**

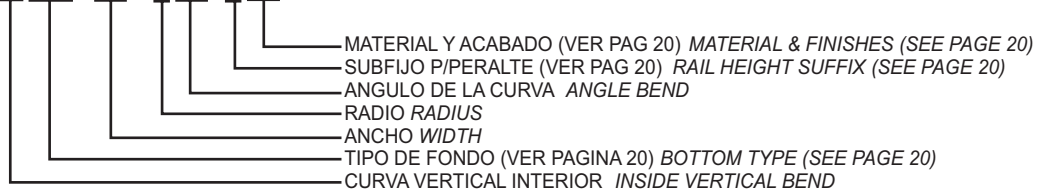

**NUMEROS DE CATALOGO PARA CURVA A 90° 90° BEND CATALOG NUMBER**

ANCHO W WIDTH W	RADIO RADIUS			
	203.2 (8)	304.8 (12)	609.6 (24)	914.4 (36)
101.6 (4)	VI**-04R890	VI**-04R1290	VI**-04R2490	VI**-04R3690
152.4 (6)	VI**-06R890	VI**-06R1290	VI**-06R2490	VI**-06R3690
228.9 (9)	VI**-09R890	VI**-09R1290	VI**-09R2490	VI**-09R3690
304.8 (12)	VI**-12R890	VI**-12R1290	VI**-12R2490	VI**-12R3690
406.4 (16)	VI**-16R890	VI**-16R1290	VI**-16R2490	VI**-16R3690
457.2 (18)	VI**-18R890	VI**-18R1290	VI**-18R2490	VI**-18R3690
508.0 (20)	VI**-20R890	VI**-20R1290	VI**-20R2490	VI**-20R3690
609.6 (24)	VI**-24R890	VI**-24R1290	VI**-24R2490	VI**-24R3690
762.0 (30)	VI**-30R890	VI**-30R1290	VI**-30R2490	VI**-30R3690
914.4 (36)	VI**-36R890	VI**-36R1290	VI**-36R2490	VI**-36R3690

**NUMEROS DE CATALOGO PARA CURVA A 45° 45° BEND CATALOG NUMBER**

ANCHO W WIDTH W	RADIO RADIUS			
	203.2 (8)	304.8 (12)	609.6 (24)	914.4 (36)
101.6 (4)	VI**-04R845	VI**-04R1245	VI**-04R2445	VI**-04R3645
152.4 (6)	VI**-06R845	VI**-06R1245	VI**-06R2445	VI**-06R3645
228.9 (9)	VI**-09R845	VI**-09R1245	VI**-09R2445	VI**-09R3645
304.8 (12)	VI**-12R845	VI**-12R1245	VI**-12R2445	VI**-12R3645
406.4 (16)	VI**-16R845	VI**-16R1245	VI**-16R2445	VI**-16R3645
457.2 (18)	VI**-18R845	VI**-18R1245	VI**-18R2445	VI**-18R3645
508.0 (20)	VI**-20R845	VI**-20R1245	VI**-20R2445	VI**-20R3645
609.6 (24)	VI**-24R845	VI**-24R1245	VI**-24R2445	VI**-24R3645
762.0 (30)	VI**-30R845	VI**-30R1245	VI**-30R2445	VI**-30R3645
914.4 (36)	VI**-36R845	VI**-36R1245	VI**-36R2445	VI**-36R3645

INCLUYE 2 CONECTORES Y TORNILLERIA TWO CONNECTORS AND HARDWARE INCLUDED  
 TODAS LAS DIMENSIONES EN mm (Pulg) ALL DIMENSIONS ARE IN mm (Inch)

**"T" HORIZONTAL**

**HORIZONTAL TEE**

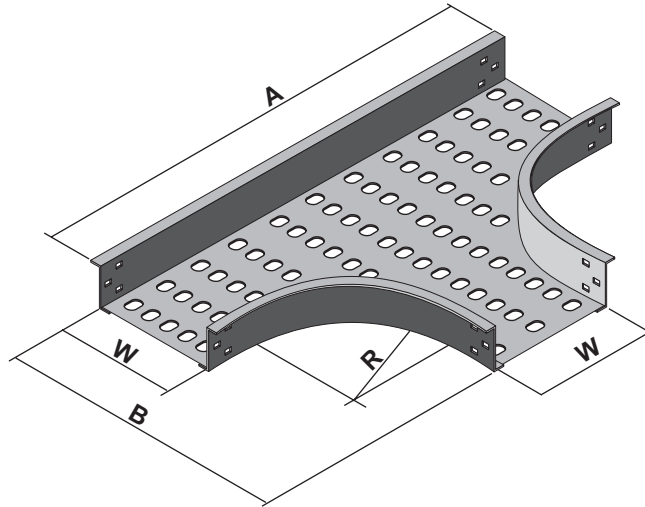

**THZL-12R8-1GI**

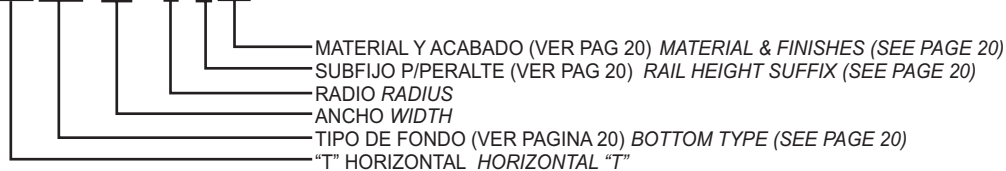

ANCHO W WIDTH W	RADIO 203.2 RADIUS (8) SOLO RADIAL RADIAL ONLY			RADIO 304.8 RADIUS (12)		
	No DE CATALOGO CATALOG NUMBER	A	B	No DE CATALOGO CATALOG NUMBER	A	B
101.6 (4)	TH**-04R8	731 (28.78)	416 (16.39)	TH**-04R12	864 (34)	518 (20.39)
152.4 (6)	TH**-06R8	782 (30.78)	467 (18.39)	TH**-06R12	914 (36)	569 (22.39)
228.9 (9)	TH**-09R8	585 (23.03)	543 (21.39)	TH**-09R12	991 (39)	645 (25.39)
304.8 (12)	TH**-12R8	934 (36.78)	619 (24.39)	TH**-12R12	1137 (44.78)	721 (28.39)
406.4 (16)	TH**-16R8	1036 (40.78)	721 (28.39)	TH**-16R12	1239 (48.78)	823 (32.39)
457.2 (18)	TH**-18R8	1086 (42.78)	772 (30.39)	TH**-18R12	1290 (50.78)	873 (34.39)
508.0 (20)	TH**-20R8	1137 (44.78)	823 (32.39)	TH**-20R12	1341 (52.78)	924 (36.39)
609.6 (24)	TH**-24R8	1239 (48.78)	924 (36.39)	TH**-24R12	1442 (56.78)	1026 (40.39)
762.0 (30)	TH**-30R8	1391 (54.78)	1077 (42.39)	TH**-30R12	1595 (62.78)	1178 (46.39)
914.4 (36)	TH**-36R8	1543 (60.78)	1229 (48.39)	TH**-36R12	1747 (68.78)	1331 (52.39)

ANCHO W WIDTH W	RADIO 609.6 RADIUS (24)			RADIO 914.4 RADIUS (36)		
	No DE CATALOGO CATALOG NUMBER	A	B	No DE CATALOGO CATALOG NUMBER	A	B
101.6 (4)	TH**-04R24	1544 (60.78)	823 (32.39)	TH**-04R36	2153 (84.78)	1127 (44.39)
152.4 (6)	TH**-06R24	1595 (62.78)	873 (34.39)	TH**-06R36	2204 (86.78)	1178 (46.39)
228.9 (9)	TH**-09R24	1671 (65.78)	950 (37.39)	TH**-09R36	2280 (89.78)	1254 (49.39)
304.8 (12)	TH**-12R24	1747 (68.78)	1030 (40.39)	TH**-12R36	2357 (92.78)	1331 (52.39)
406.4 (16)	TH**-16R24	1849 (72.78)	1127 (44.39)	TH**-16R36	2458 (96.78)	1432 (56.39)
457.2 (18)	TH**-18R24	1899 (74.78)	1178 (46.39)	TH**-18R36	2509 (98.78)	1483 (58.39)
508.0 (20)	TH**-20R24	1950 (76.78)	1229 (48.39)	TH**-20R36	2560 (100.78)	1534 (60.39)
609.6 (24)	TH**-24R24	2052 (80.78)	1331 (52.39)	TH**-24R36	2661 (104.78)	1635 (64.39)
762.0 (30)	TH**-30R24	2204 (86.78)	1483 (58.39)	TH**-30R36	2814 (110.78)	1788 (70.39)
914.4 (36)	TH**-36R24	2357 (92.78)	1635 (64.39)	TH**-36R36	2966 (116.78)	1940 (76.39)

INCLUYE 2 CONECTORES Y TORNILLERIA TWO CONNECTORS AND HARDWARE INCLUDED

TODAS LAS DIMENSIONES EN mm (Pulg) ALL DIMENSIONS ARE IN mm (Inch)

**"X" HORIZONTAL**

**HORIZONTAL CROSS**

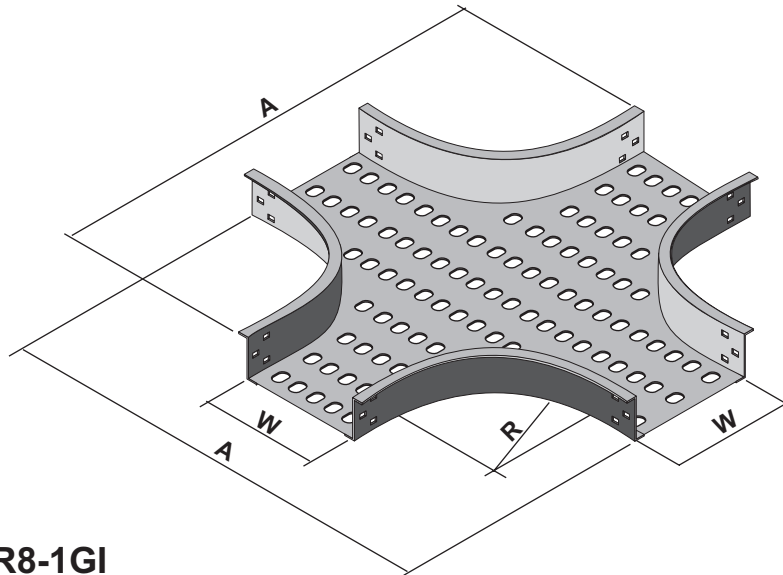

**XHZL-12R8-1GI**

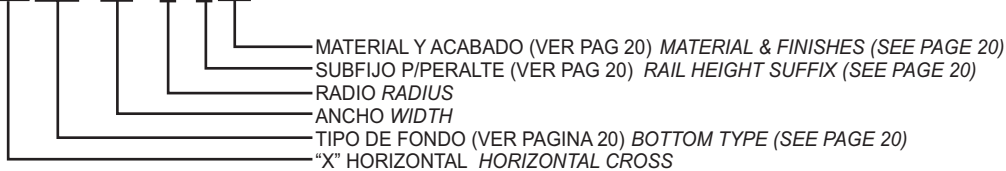

ANCHO W WIDTH W	RADIO 203.2 RADIUS (8)		RADIO 304.8 RADIUS (12)	
	No DE CATALOGO CATALOG NUMBER	A	No DE CATALOGO CATALOG NUMBER	A
101.6 (4)	XH**-04R8	731 (28.78)	XH**-04R12	864 (34)
152.4 (6)	XH**-06R8	782 (30.78)	XH**-06R12	914 (36)
228.9 (9)	XH**-09R8	585 (23.03)	XH**-09R12	991 (39)
304.8 (12)	XH**-12R8	934 (36.78)	XH**-12R12	1137 (44.78)
406.4 (16)	XH**-16R8	1036 (40.78)	XH**-16R12	1239 (48.78)
457.2 (18)	XH**-18R8	1086 (42.78)	XH**-18R12	1290 (50.78)
508.0 (20)	XH**-20R8	1137 (44.78)	XH**-20R12	1341 (52.78)
609.6 (24)	XH**-24R8	1239 (48.78)	XH**-24R12	1442 (56.78)
762.0 (30)	XH**-30R8	1391 (54.78)	XH**-30R12	1595 (62.78)
914.4 (36)	XH**-36R8	1543 (60.78)	XH**-36R12	1747 (68.78)

ANCHO W WIDTH W	RADIO 609.6 RADIUS (24)		RADIO 914.4 RADIUS (36)	
	No DE CATALOGO CATALOG NUMBER	A	No DE CATALOGO CATALOG NUMBER	A
101.6 (4)	XH**-04R24	1544 (60.78)	XH**-04R36	2153 (84.78)
152.4 (6)	XH**-06R24	1595 (62.78)	XH**-06R36	2204 (86.78)
228.9 (9)	XH**-09R24	1671 (65.78)	XH**-09R36	2280 (89.78)
304.8 (12)	XH**-12R24	1747 (68.78)	XH**-12R36	2357 (92.78)
406.4 (16)	XH**-16R24	1849 (72.78)	XH**-16R36	2458 (96.78)
457.2 (18)	XH**-18R24	1899 (74.78)	XH**-18R36	2509 (98.78)
508.0 (20)	XH**-20R24	1950 (76.78)	XH**-20R36	2560 (100.78)
609.6 (24)	XH**-24R24	2052 (80.78)	XH**-24R36	2661 (104.78)
762.0 (30)	XH**-30R24	2204 (86.78)	XH**-30R36	2814 (110.78)
914.4 (36)	XH**-36R24	2357 (92.78)	XH**-36R36	2966 (116.78)

INCLUYE 2 CONECTORES Y TORNILLERIA TWO CONNECTORS AND HARDWARE INCLUDED  
 TODAS LAS DIMENSIONES EN mm (Pulg) ALL DIMENSIONS ARE IN mm (Inch)

**"T" VERTICAL**

**VERTICAL TEE**

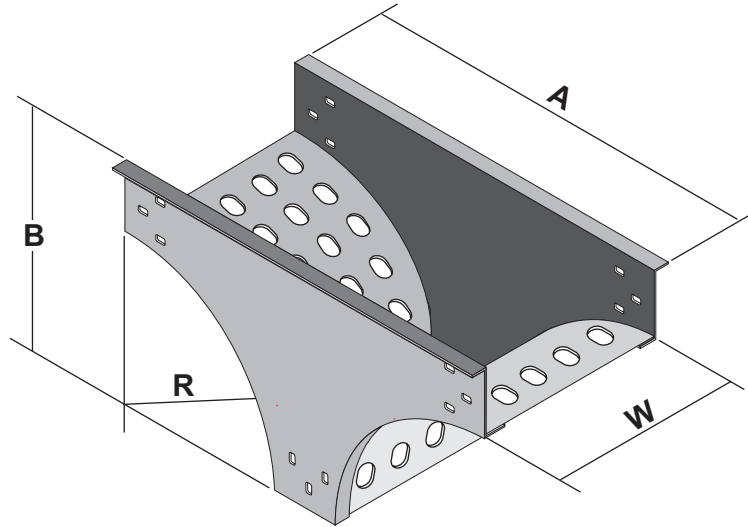

**TVZP-12R8-1GI**

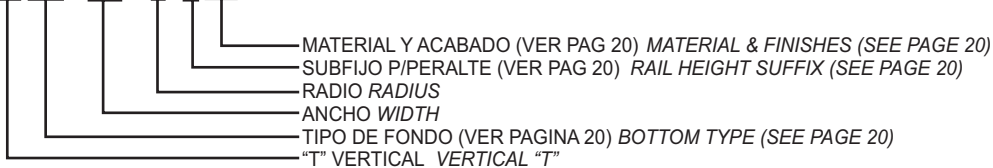

**NUMEROS DE CATALOGO CATALOG NUMBER**

ANCHO W WIDTH W	RADIO RADIUS			
	203.2 (8)	304.8 (12)	609.6 (24)	914.4 (36)
101.6 (4)	TV**-04R8	TV**-04R12	TV**-04R24	TV**-04R36
152.4 (6)	TV**-06R8	TV**-06R12	TV**-06R24	TV**-06R36
228.9 (9)	TV**-09R8	TV**-09R12	TV**-09R24	TV**-09R36
304.8 (12)	TV**-12R8	TV**-12R12	TV**-12R24	TV**-12R36
406.4 (16)	TV**-16R8	TV**-16R12	TV**-16R24	TV**-16R36
457.2 (18)	TV**-18R8	TV**-18R12	TV**-18R24	TV**-18R36
508.0 (20)	TV**-20R8	TV**-20R12	TV**-20R24	TV**-20R36
609.6 (24)	TV**-24R8	TV**-24R12	TV**-24R24	TV**-24R36
762.0 (30)	TV**-30R8	TV**-30R12	TV**-30R24	TV**-30R36
914.4 (36)	TV**-36R8	TV**-36R12	TV**-36R24	TV**-36R36

SUBFIJO P/PERALTE HEIGHT RAIL SUFFIX	RADIO RADIUS							
	203.2 (8)		304.8 (12)		609.6 (24)		914.4 (36)	
	A	B	A	B	A	B	A	B
1	489 (19.25)	286 (11.25)	692 (27.25)	387 (15.25)	1302 (51.25)	692 (27.25)	1911 (75.25)	997 (39.25)
2	508 (20)	305 (12)	711 (28)	406 (16)	1321 (52)	711 (28)	1930 (76)	1016 (40)
3	521 (20.5)	318 (12.5)	724 (28.5)	419 (16.5)	1334 (52.5)	724 (28.5)	1943 (76.5)	1029 (40.5)
5	533 (21)	330 (13)	737 (29)	432 (17)	1346 (53)	737 (29)	1956 (77)	1041 (41)
6	559 (22)	356 (14)	762 (30)	457 (18)	1372 (54)	762 (30)	1981 (78)	1067 (42)

INCLUYE 2 CONECTORES Y TORNILLERIA TWO CONNECTORS AND HARDWARE INCLUDED

TODAS LAS DIMENSIONES EN mm (Pulg) ALL DIMENSIONS ARE IN mm (Inch)

**CURVA HORIZONTAL AJUSTABLE**

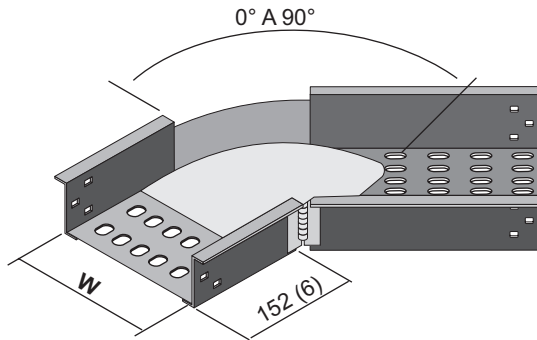

**HORIZONTAL ADJUSTABLE BEND**

ANCHO W WIDTH W	N° DE CATALOGO CATALOG NUMBER
101.6 (4)	CA**-04
152.4 (6)	CA**-06
228.9 (9)	CA**-09
304.8 (12)	CA**-12
406.4 (16)	CA**-16
457.2 (18)	CA**-18
508.0 (20)	CA**-20
609.6 (24)	CA**-24
762.0 (30)	CA**-30
914.4 (36)	CA**-36

INCLUYE 2 CONECTORES Y TORNILLERIA  
TWO CONNECTORS AND HARDWARE INCLUDED

NO INCLUYE CINTAS CONDUCTORAS  
BONDING JUMPERS NOT INCLUDED

**CAZP-12-1GI**

- MATERIAL Y ACABADO (VER PAG 20) MATERIAL & FINISHES (SEE PAGE 20)
- SUBFIJO P/PERALTE (VER PAG 20) RAIL HEIGHT SUFFIX (SEE PAGE 20)
- ANCHO WIDTH
- TIPO DE FONDO (VER PAGINA 20) BOTTOM TYPE (SEE PAGE 20)
- CURVA HORIZONTAL AJUSTABLE HORIZONTAL ADJUSTABLE BEND

**DERIVACION HORIZONTAL A 45°**

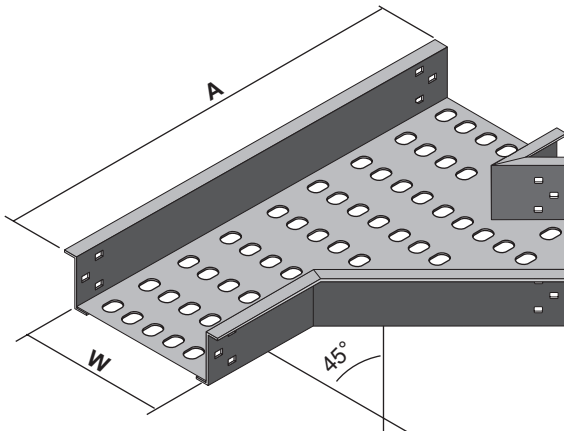

**45° HORIZONTAL WYE**

ANCHO W WIDTH W	N° DE CATALOGO CATALOG NUMBER	A
101.6 (4)	DY**-04	463 (18.2)
152.4 (6)	DY**-06	534 (21)
228.9 (9)	DY**-09	642 (25.3)
304.8 (12)	DY**-12	750 (29.5)
406.4 (16)	DY**-16	894 (35.2)
457.2 (18)	DY**-18	966 (38)
508.0 (20)	DY**-20	1037 (40.8)
609.6 (24)	DY**-24	1181 (46.5)
762.0 (30)	DY**-30	1396 (55)
914.4 (36)	DY**-36	1612 (63.5)

INCLUYE 2 CONECTORES Y TORNILLERIA  
TWO CONNECTORS AND HARDWARE INCLUDED

**DYZP-12-1GI**

- MATERIAL Y ACABADO (VER PAG 20) MATERIAL & FINISHES (SEE PAGE 20)
- SUBFIJO P/PERALTE (VER PAG 20) RAIL HEIGHT SUFFIX (SEE PAGE 20)
- ANCHO WIDTH
- TIPO DE FONDO (VER PAGINA 20) BOTTOM TYPE (SEE PAGE 20)
- DERIVACION HORIZONTAL A 45° 45° HORIZONTAL WYE

TODAS LAS DIMENSIONES EN mm (Pulg) ALL DIMENSIONS ARE IN mm (Inch)

**REDUCCIONES**

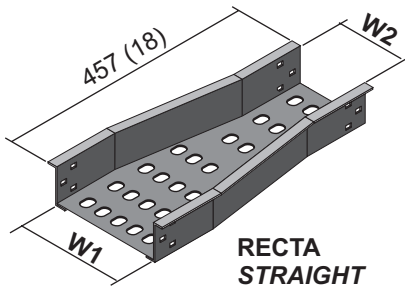

**RECTA  
STRAIGHT**

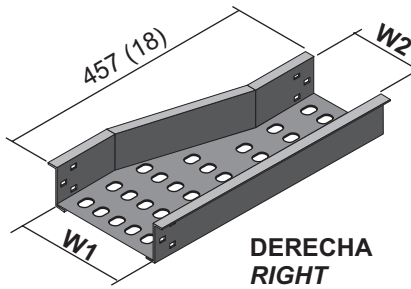

**DERECHA  
RIGHT**

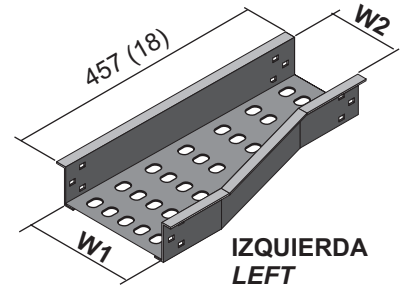

**IZQUIERDA  
LEFT**

**REDUCERS**

**RLZL-1209-1GI**

- MATERIAL Y ACABADO (VER PAG 20) MATERIAL & FINISHES (SEE PAGE 20)
- SUBFIJO P/PERALTE (VER PAG 20) RAIL HEIGHT SUFFIX (SEE PAGE 20)
- ANCHO MENOR SMALLER WIDTH
- ANCHO MAYOR LARGER WIDTH
- TIPO DE FONDO (VER PAGINA 20) BOTTOM TYPE (SEE PAGE 20)
- REDUCCION REDUCER
- RL = RECTA STRAIGHT
- RLD = DERECHA RIGHT
- RLI = IZQUIERDA LEFT

**Nº DE CATALOGO REDUCCIONES RECTAS STRAIGHT REDUCER CATALOG NUMBER**

ANCHO W1 WIDTH W1	ANCHO MENOR W2 SMALLER WIDTH W2								
	101.6 (4)	152.4 (6)	228.9 (9)	304.8 (12)	406.4 (16)	457.2 (18)	508.0 (20)	609.6 (24)	762.0 (36)
152.4 (6)	RL**-0604								
228.9 (9)	RL**-0904	RL**-0906							
304.8 (12)	RL**-1204	RL**-1206	RL**-1209						
406.4 (16)	RL**-1604	RL**-1606	RL**-1609	RL**-1612					
457.2 (18)	RL**-1804	RL**-1806	RL**-1809	RL**-1812	RL**-1816				
508.0 (20)	RL**-2004	RL**-2006	RL**-2009	RL**-2012	RL**-2016	RL**-2018			
609.6 (24)	RL**-2404	RL**-2406	RL**-2409	RL**-2412	RL**-2416	RL**-2418	RL**-2420		
762.0 (30)	RL**-3004	RL**-3006	RL**-3009	RL**-3012	RL**-3016	RL**-3018	RL**-3020	RL**-3024	
914.4 (36)	RL**-3604	RL**-3606	RL**-3609	RL**-3612	RL**-3616	RL**-3618	RL**-3620	RL**-3624	RL**-3630

**Nº DE CATALOGO REDUCCIONES DERECHAS RIGHT REDUCER CATALOG NUMBER**

ANCHO W1 WIDTH W1	ANCHO MENOR W2 SMALLER WIDTH W2								
	101.6 (4)	152.4 (6)	228.9 (9)	304.8 (12)	406.4 (16)	457.2 (18)	508.0 (20)	609.6 (24)	762.0 (36)
152.4 (6)	RLD**-0604								
228.9 (9)	RLD**-0904	RLD**-0906							
304.8 (12)	RLD**-1204	RLD**-1206	RLD**-1209						
406.4 (16)	RLD**-1604	RLD**-1606	RLD**-1609	RLD**-1612					
457.2 (18)	RLD**-1804	RLD**-1806	RLD**-1809	RLD**-1812	RLD**-1816				
508.0 (20)	RLD**-2004	RLD**-2006	RLD**-2009	RLD**-2012	RLD**-2016	RLD**-2018			
609.6 (24)	RLD**-2404	RLD**-2406	RLD**-2409	RLD**-2412	RLD**-2416	RLD**-2418	RLD**-2420		
762.0 (30)	RLD**-3004	RLD**-3006	RLD**-3009	RLD**-3012	RLD**-3016	RLD**-3018	RLD**-3020	RLD**-3024	
914.4 (36)	RLD**-3604	RLD**-3606	RLD**-3609	RLD**-3612	RLD**-3616	RLD**-3618	RLD**-3620	RLD**-3624	RLD**-3630

**Nº DE CATALOGO REDUCCIONES IZQUIERDAS LEFT REDUCER CATALOG NUMBER**

ANCHO W1 WIDTH W1	ANCHO MENOR W2 SMALLER WIDTH W2								
	101.6 (4)	152.4 (6)	228.9 (9)	304.8 (12)	406.4 (16)	457.2 (18)	508.0 (20)	609.6 (24)	762.0 (36)
152.4 (6)	RLI**-0604								
228.9 (9)	RLI**-0904	RLI**-0906							
304.8 (12)	RLI**-1204	RLI**-1206	RLI**-1209						
406.4 (16)	RLI**-1604	RLI**-1606	RLI**-1609	RLI**-1612					
457.2 (18)	RLI**-1804	RLI**-1806	RLI**-1809	RLI**-1812	RLI**-1816				
508.0 (20)	RLI**-2004	RLI**-2006	RLI**-2009	RLI**-2012	RLI**-2016	RLI**-2018			
609.6 (24)	RLI**-2404	RLI**-2406	RLI**-2409	RLI**-2412	RLI**-2416	RLI**-2418	RLI**-2420		
762.0 (30)	RLI**-3004	RLI**-3006	RLI**-3009	RLI**-3012	RLI**-3016	RLI**-3018	RLI**-3020	RLI**-3024	
914.4 (36)	RLI**-3604	RLI**-3606	RLI**-3609	RLI**-3612	RLI**-3616	RLI**-3618	RLI**-3620	RLI**-3624	RLI**-3630

INCLUYE 2 CONECTORES Y TORNILLERIA TWO CONNECTORS AND HARDWARE INCLUDED  
 TODAS LAS DIMENSIONES EN mm (Pulg) ALL DIMENSIONS ARE IN mm (Inch)